

REV	DESCRIPTION	DRAWN	DATE

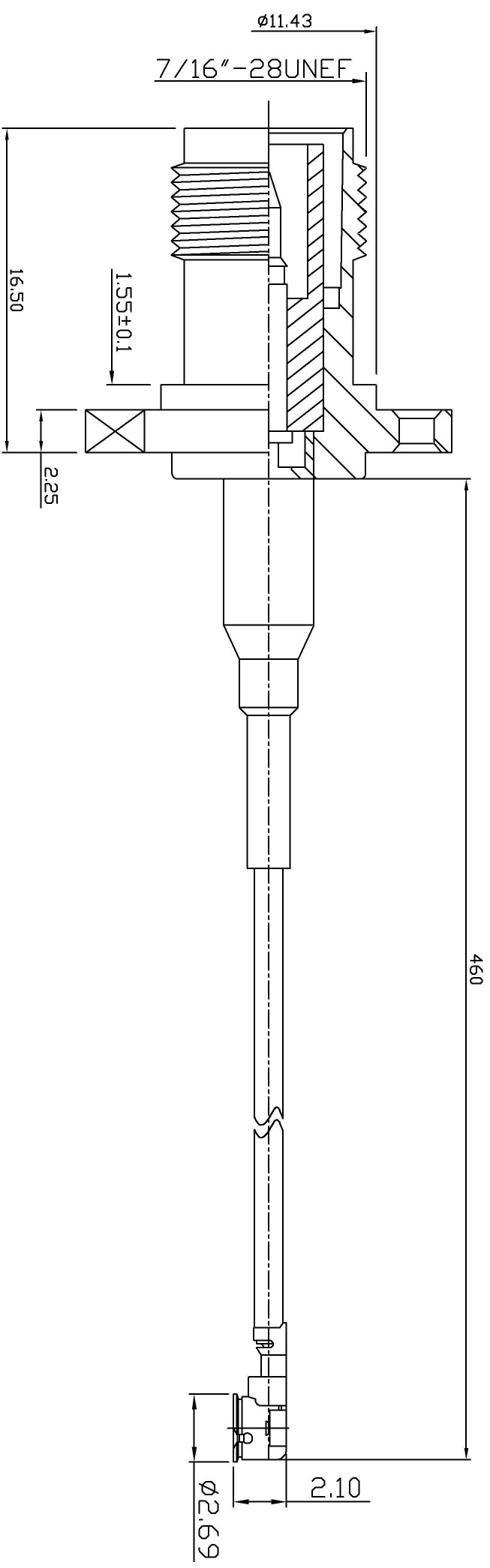

No	Description	Qty	Material	Finish
3	IPEX-2601-1-1-DGG	1	BRASS	GOLD
2	I-PEX132	1		
1	TNC-1516-1-M-RP-TGN	1	BRASS	NICKEL

UNLESS OTHERWISE SPECIFIED
 1.REMOVE ALL BURRS,
 2.BREAK ALL CONNERS &
 EDGES CO 15 MAX
 3.CHAMFER 1ST & LAST
 THREADS 45°
 4.DIAMETERS ON COMMON
 CENTERS
 TO BE CONCENTRIC
 WITHIN 0.1 TYP
 5.ALL DIMENSIONS ARE
 AFTER PLATING.

SCALE	5/2	UNIT	MM
UNLESS OTHERWISE NOTED TOLERANCES	0.5-6 = ± 0.2		
	6-30 = ± 0.4		
	30-120 = ± 0.6		
	120-315 = ± 1.0		
	ANGLES = ± 1.0		

APPROVED	CHECKED	DRAWN	DRAWN DATE
		CHAI	06/07/06

TITLE	DRAWING NO.	REV
TNC1516-1-PEX2601	1516113226011-L460	A

FILE NO. D:\DWG\TNC1516-1-PEX2601\1516113226011-L460